



QFA1001



QFA1000

Room Hygrostats

QFA1...

for relative humidity

- Hygrostat with single-pole microswitch
- Humidity measuring element made of stabilized plastic texture
- Setpoint knob for the upper switching point
- For controlling humidification equipment
- For controlling dehumidification equipment
- For mounting directly on the wall or on a recessed conduit box

Use

The room hygrostats are used for controlling and monitoring relative humidity in ventilation or air conditioning plant.

They ensure room humidity control within the selectable range of 30 to 90 % relative humidity by controlling humidification or dehumidification equipment.

They can also be used for monitoring minimum or maximum humidity levels.

Type summary

Type reference	Setpoint setting range	Switching differential ¹⁾		Setpoint knob
		Statically	Dynamically	
QFA1000	30...90 % r. h.	Approx. 4 % r.h.	6 % r.h.	Internally
QFA1001	30...90 % r. h.	Approx. 4 % r.h.	6 % r.h.	Externally

1) The static switching differential is determined at a constant ambient humidity by turning the setting knob.

The dynamic switching differential is determined by changing the ambient humidity while maintaining the same setpoint adjustment; only the dynamic switching differential is of practical value.

Ordering

When ordering, please give name and type reference, e.g.:
Room hygrostat **QFA1001**

Mode of operation

The room hygrostat acquires the relative humidity of the ambient air via its humidity measuring element, which is made of stabilized plastic texture. This plastic band actuates a microswitch depending on the relative humidity. The microswitch has a fixed switching differential X_{Sd} and a potential-free contact output. If the actual humidity deviates from the adjusted setpoint, the hygrostat switches the humidification or dehumidification equipment as shown in the following function diagram.

Function diagram

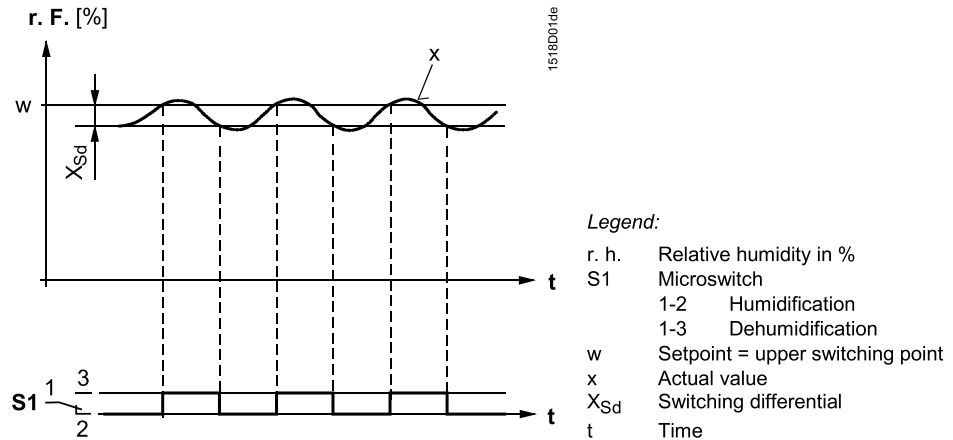

Due to the measuring element's aging effect, the switching point drifts slowly and constantly. For this reason, recalibration may be required in due time.

At temperatures other than the calibration temperature, the switching point drifts systematically (temperature influence). Also, in the case of fast humidity changes, the switching point will temporarily be shifted.

Mechanical design

QFA1001

The room hygrostat is designed for wall mounting. It fits on most commercially available recessed conduit boxes. The cables are introduced either from the rear (recessed conduit boxes) or from above (surface-run wires), after knocking out the cable inlet tongues.

The unit consists of base and cover.

Base and cover can be separated (snap-on connection).

The base accommodates the humidity measuring element, setpoint setting element with setting spindle, scale, microswitch and screw terminals.

The cover carries the removable setpoint knob with its imprinted scale.

QFA1000

This model is of the same basic design as the QFA1001, but there is no external setpoint knob. The setpoint can only be adjusted when the cover is removed.

Operating elements

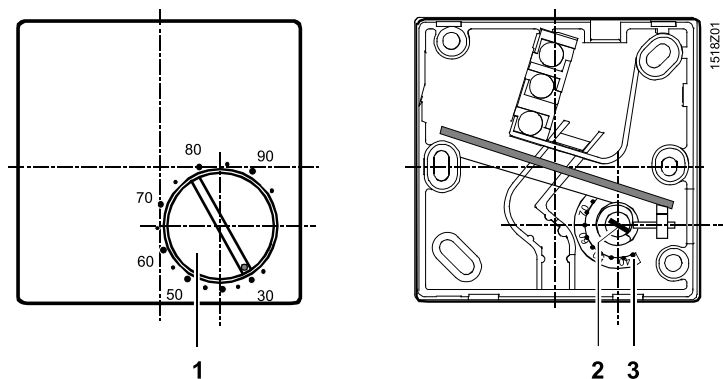

Legend

- 1 Setpoint knob with scale – only with QFA1001
- 2 Setpoint setting spindle
- 3 Scale for setpoint adjustment with QFA1000

Mounting notes

Mounting choices

The base has cable entries at the rear for mounting the room hygrometer on recessed conduit boxes. In the case of wall mounting, appropriate holes at the top or bottom can be knocked out.

Mounting location

The unit should be mounted about 1.5 meters above the floor and at least 0.5 meters from the closest wall.

Natural circulation of room air must be ensured at the location where the hygrometer is mounted (no drafts, not in corners, not behind curtains, not in the vicinity of doors and windows, and not on outer walls). Sources of heat or refrigeration (radiators, computers, TV sets, concealed heating pipes, hot and cold water pipes) must be located at adequate distances.

The unit must not be exposed to direct solar radiation.

Mounting Instructions

The room hygrometer is supplied complete with Mounting Instructions.

Disposal



The devices are considered electronics devices for disposal in term of European Directive 2012/19/EU and may not be disposed of as domestic waste.

- Dispose of the device via the channels provided for this purpose.
- Comply with all local and currently applicable laws and regulations.

Technical data

Functional data	Setpoint setting range	30...90 %
	Humidity measuring element	stabilized plastic texture band
	Control mode	2-position
	Time constant ($v = 0.2 \text{ m/s}$)	approx. 5 min
	Switching differential X_{Sd}	refer to "Type summary"
	Setting accuracy ¹⁾	$\pm 5 \%$ r.h.
	Temperature influence	+0.5 % r.h./K
	Humidity calibration at	55 % r.h., 23 °C
	Long-term stability	approx. -1.5 % r.h./a
	Type of switch	microswitch (1-pole potential-free changeover switch)
	Contact rating	
	Maximum	5(3) A, AC 250 V
	Minimum	100 mA, AC 24 V
External protection	Fuse slow max. T5A	
Degree of protection	Protection degree of housing	IP20 according to EN 60529
	Protection class	II according to EN 60730-1
Electrical connection	Screw terminals for	max. $2 \times 1.5 \text{ mm}^2$

Environmental conditions	Perm. ambient temperature	0...40 °C
	Noncondensing	-25...+40 °C
Materials and colors	Base	PPS Fortron, glassfiber-reinforced, black
	Cover	PC Lexan 940, pure-white
	Humidity measuring element	plastic texture
Directives and Standards	Product standard	EN 60730-1
		Automatic electrical controls for household and similar use
Weight	EU Conformity (CE)	CE1T1518xx ²⁾
	QFA1001	0.090 kg
	QFA1000	0.090 kg

1) Can be improved by recalibrating on site

2) The documents can be downloaded from <http://siemens.com/bt/download>.

Connection diagrams

Internal diagram

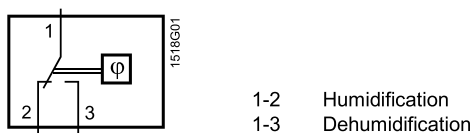

Connection diagrams

Diagram 1: Humidification

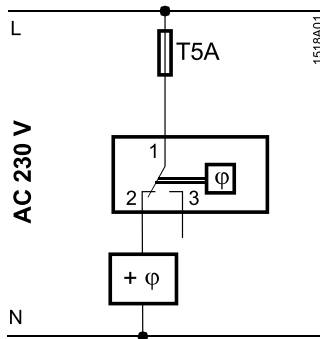
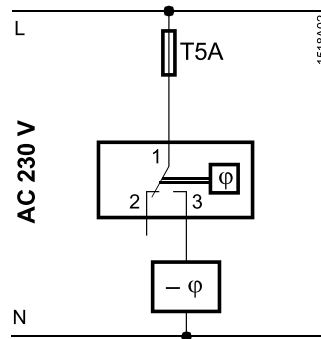
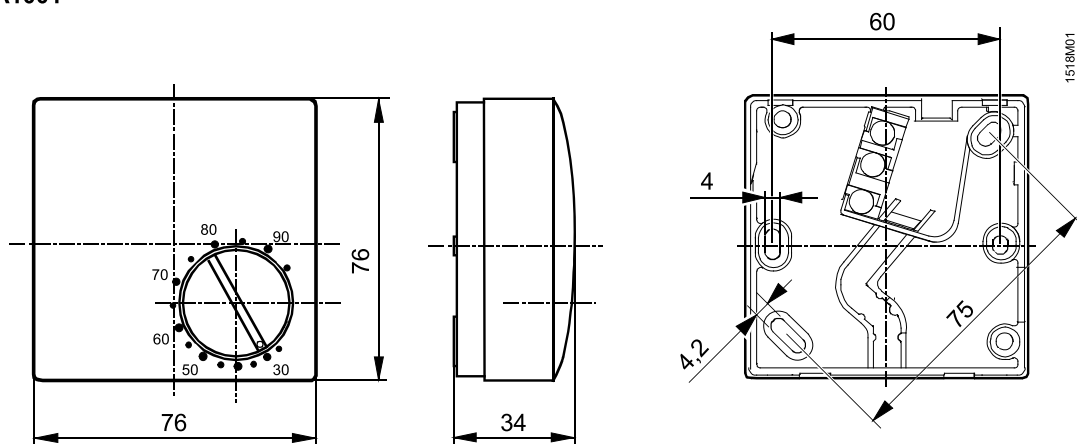

Diagram 2: Dehumidification



Dimensions

QFA1000, QFA1001



Dimensions in mm