

Series HE-CDT and HE-CDTR Wall Mount Carbon Dioxide/ Temperature Transmitter

Specifications - Installation and Operating Instructions

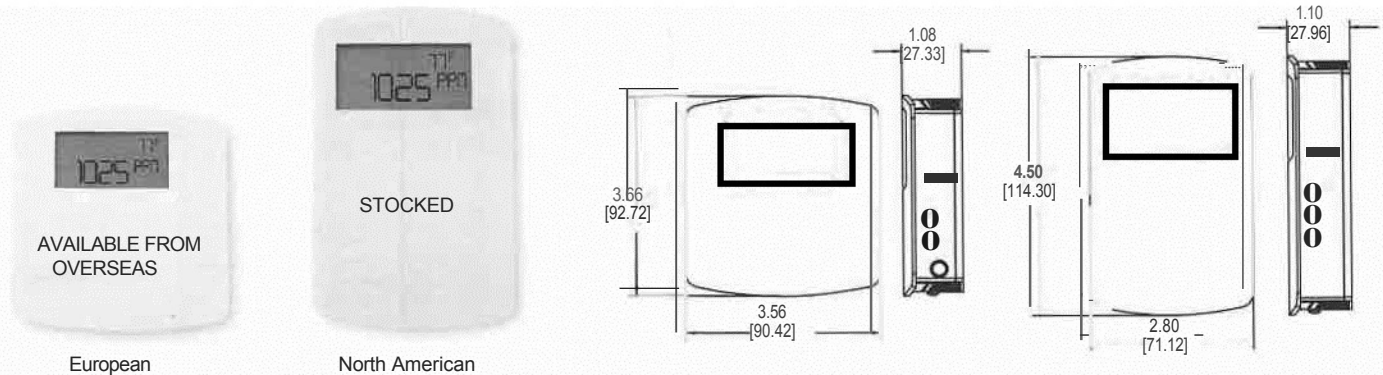

Series CDT and CDTR Wall Mount Carbon Dioxide Temperature Transmitters

accurately monitor the CO₂ concentration and temperature in schools, office buildings, and other indoor environments to help achieve LEED certification. Additionally, the Series CDTR also measures ambient relative humidity. For increased sensor life, a single-beam dual-wavelength non-dispersive infrared (NDIR) sensor is used to automatically correct the measurement in both occupied and unoccupied buildings against aging effects. The single-beam dual-wavelength sensor technology provides the highest level of accuracy compared to Automatic Baseline Correction methods, which can unintentionally shift the calibration based on CO₂ levels and barometric pressure conditions. In order to achieve a higher level of accuracy, the Series CDT includes digital barometric pressure adjustment and the ability to field-calibrate the sensor.

Universal outputs allow users to select the transmitter output to be 4 to 20 mA, 0 to 5 VDC, or 0 to 10 VDC to work with virtually any building management controller. An optional relay with user adjustable set points can be used to control exhaust fans, open actuated windows or dampers, or signal a light or horn.

For applications that require visual indication, the Series CDT and CDTR can be ordered with an integral LCD display, Model A-449 or Model A-449A remote LCD display that can plug into the mini-connector port on the side of the transmitter. Both the CDT and CDTR can be configured to display temperature only, CO₂ only, or CO₂ and temperature together. The Series CDTR can also display relative humidity or CO₂ and relative humidity together. Push buttons are standard on the transmitters for access to the menu structure, but the transmitter can be ordered without the buttons. To prevent tampering, the action of the buttons can be locked out using an internal dip switch selection. Menu items that can be accessed include: engineering units, relay output set points, display configuration, transmitter output scaling, ambient barometric pressure and field calibration of the transmitter.

Single-beam dual-wavelength sensor advantages:

- Automatically corrects for aging effects in occupied and unoccupied buildings*
 - Perfect for hospitals and manufacturing plants that are occupied 24 hours per day
- Measures actual unfiltered light intensity directly
 - Eliminates error from incorrect assumptions of gas concentration in theoretical logic assumption methods
- For buildings occupied 24 hours per day, it is recommended that calibration be verified every 6 to 12 months depending on application.

SPECIFICATIONS

Sensor: Single beam, dual-wavelength NDIR.
Range: CO₂: 0 to 2000 or 0 to 5000 ppm (depending on model); Temperature: 32 to 122°F (0 to 50°C).
Accuracy: CO₂: ±40 ppm ±3% of reading; RH: ±2% (10 to 90% RH) (for units configured with humidity output); Temperature: ±1°C @ 25°C.
Temperature Dependence: ±8 ppm/°C at 1100 ppm.
Non-Linearity: 16 ppm,
Pressure Dependence: 0.13% of reading per mm of Hg,
Response Time: 2 min for 99% step change.
Temperature Limits: 32 to 122°F (0 to 50°C).
Humidity Limits: 10 to 95% RH (non-condensing).
Power Requirements: 16 to 35 VDC or 19 to 28 VAC.
Power Consumption: Average: 2 w, Peak: 3.75 w
Output: Current: 4 to 20 mA (max. 500 Ω); Voltage: 0 to 5 VDC or 0 to 10 VDC (min. 500 Ω); Relay: SPST NO rated 2A @ 30 VDC; RTD or thermistor per r-t curves on page 4 (depending on model).
Weight: 4.4 oz (125 g).
Agency Approvals: CE.

INSTALLATION

CAUTION

Disconnect power supply before installation to prevent electrical shock and equipment damage.

Make sure all connections are in accordance with the job wiring diagram and in accordance with national and local electrical codes. Use copper conductors only.

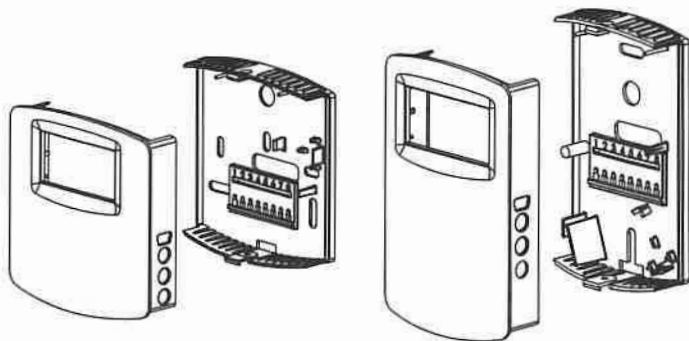

Figure 1: Removal Of Cover From Back Plate

MOUNTING

1. Push tab on top and bottom of cover and lift cover from back plate (See Figure 1).
2. Select the mounting location, away from diffusers, lights or any external influences.
3. Mount transmitter on a vertical surface to a standard electrical box using the two #6 M2C type screws provided.
4. Pull wires through sub base hole and make necessary connections.
5. Reattach cover to base plate.

WIRING

Use maximum 18 AWG wire for wiring to terminals. Refer to Figure 4 for wiring information.

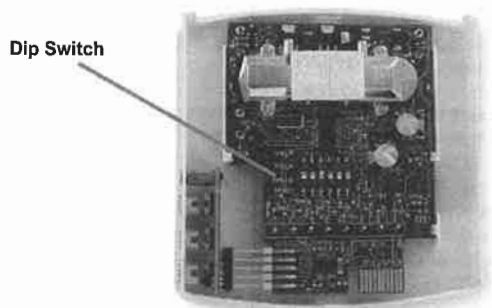

Figure 2: Diagram Of Circuit Board

DIP SWITCH SETTINGS

To access the DIP SWITCH, remove the cover of the unit as shown in Figure 2. The DIP SWITCH is located on the back of the circuit board.

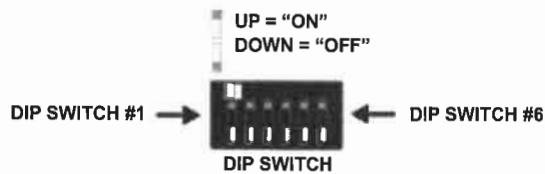

Figure 3

DIP Switch Position 1: CO₂ Output Selection

ON: Output set to voltage output
OFF: Output set to current output

DIP Switch Position 2: Temperature (CDT models) / Humidity (CDTR models) Output Selection

ON: Output set to voltage output
OFF: Output set to current output

DIP Switch Positions 3 & 4: Current or Voltage Output Range Selection

Output Range	DIP Switch 3 Position	DIP Switch 4 Position
2 to 10 V 4 to 20 mA	ON	OFF
0 to 10 V 0 to 20 mA	OFF	OFF
0 to 5 V 0 to 10 mA	OFF	ON
1 to 5 V 2 to 10 mA	ON	ON

Dip Switch Position 5: Menu Access

ON: Menu Enabled
OFF: Menu Disabled

Current / Voltage Outputs

On the Series CDT, the transmitter may be wired for current or voltage output for both carbon dioxide and temperature. On the Series CDTR, the transmitter may be wired for current or voltage output for both carbon dioxide and humidity. The transmitter can be powered with either 16 to 35 VDC or 19 to 28 VAC. Wire the transmitter according to Figure 4.

NOTICE Optional relay can be used as either a dry contact or low voltage switched circuit up to 2 A at 30 VDC

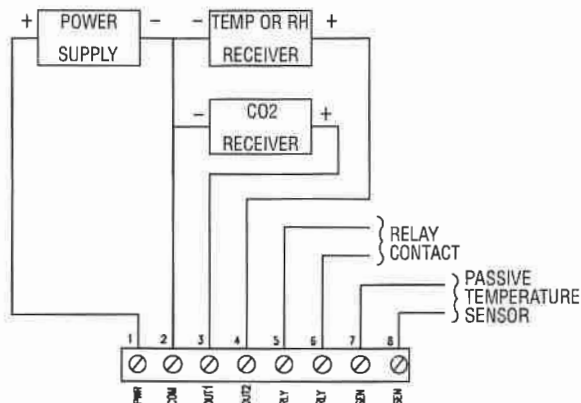

Figure 4: Active Output Wiring Diagram

Remote Display

For models that are ordered without an integral LCD display, remote display Model A-449 can be used to display the temperature, humidity, and carbon dioxide. The mini USB plug of the remote display plugs into the receptor on the side of the housing. After a short warm up time, the display will begin to show the current temperature and carbon dioxide measurements unless configured by the user to show humidity and carbon dioxide, only temperature, only humidity, or only carbon dioxide.

EDITING MENU PARAMETERS

Before any adjustment can be made to the transmitter, the Menu Lockout Dip Switch must be set to the "On" position (See Figure 3)

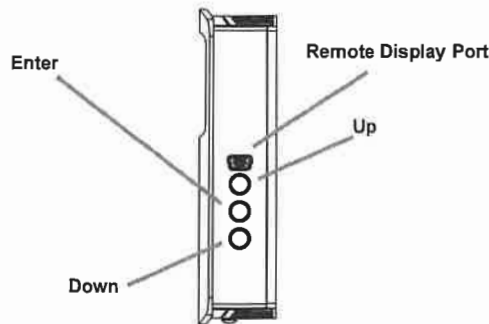

Figure 5: Side View of Transmitter

ACCESSING MENU PARAMETERS

- Step 1: To enter the menu structure, press Up button and Down button simultaneously for 5 seconds (display will show RON parameter).
- Step 2: Press Up button or Down button to cycle between menu items.
- Step 3: Press Enter to edit the value for the displayed menu item (SET will appear on display).
- Step 4: Press Up button or Down button to adjust the value of the menu item.
- Step 5: Press Enter button to save the changes (SET will disappear).
- Step 6: Repeat Steps 2 through 5 for each of the parameters.
- Step 7: To exit the menu at any time, press and hold Up button and Down button simultaneously for 5 seconds or wait 10 seconds without pushing any buttons.

MAINTENANCE/REPAIR

Upon final installation of the Series CDT and CDTR, no routine maintenance is required. The Series CDT and CDTR are not field serviceable and should be returned if repair is needed. Field repair should not be attempted and may void warranty.



This symbol indicates waste electrical products should not be disposed of with household waste. Please recycle where facilities exist. Check with your Local Authority or retailer for recycling advice.

WARRANTY/RETURN

Refer to "Terms and Conditions of Sales" in our catalog and on our website. Contact customer service to receive a Return Goods Authorization number before shipping the product back for repair. Be sure to include a brief description of the problem plus any additional application notes.

HEVAC STOCK CDT-2N44-LCD-RLY

Series	CDT	-2	N	4	4	-LCD	Example: CDT-2N44-LCD
Range		2 5					0 to 2000 ppm CO ₂ range 0 to 5000 ppm CO ₂ range
Configuration			N E				North American Wall Mount European Wall Mount
CO ₂ Output				4			4 to 20 mA / 0 to (5 or 10) VDC
Temperature Output					0 4 A B C D E F		None 4 to 20 mA / 0 to (5 or 10) VDC 10 KΩ NTC thermistor type III 10 KΩ NTC thermistor type II 3 KΩ NTC thermistor Pt100 Ω RTD Pt1000 Ω RTD 20 KΩ NTC thermistor
Options						LCD RLY NBC	LCD display (wall only) Relay No buttons (wall only)

Figure 7: Series CDT Model Chart

0-10VDC TEMP O/P
0-10VDC CO₂ O/P
c/w LCD DISPLAY
& CONTROL RELAY

US Customary Units	
ft	in Hg
0	29.92
400	29.50
800	29.10
1200	28.69
1600	28.29
2000	27.90
2400	27.51
2800	27.13
3200	26.76
3600	26.39
4000	26.02
4400	25.66
4800	25.30
5200	24.95
5600	24.60
6000	24.26
6400	23.93
6800	23.60
7200	23.27
7600	22.94
8000	22.63
8400	22.31
8800	22.00
9200	21.70
9600	21.40
10000	21.40

SI Units	
m	hPa
0	1013
100	1002
200	990
300	979
400	968
500	957
600	946
700	935
800	924
900	914
1000	904
1100	893
1200	883
1300	873
1400	863
1500	853
1600	844
1700	834
1800	824
1900	815
2000	806
2100	797
2200	787
2300	779
2400	770
2500	761

Figure 9: Elevation Chart

RESISTANCE VS TEMPERATURE TABLE

Temperature		Resistance Curves (In Ohms)					
°C	°F	A	B	C	D	E	F
-55	-67.0	607800.00	963849.00	289154.70	78.32	783.2	2394000.00
-50	-58.0	441200.00	670166.00	201049.80	80.31	803.1	1646200.00
-45	-49.0	323600.00	471985.00	141595.50	82.29	822.9	1145800.00
-40	-40.0	239700.00	336479.00	100943.70	84.27	842.7	806800.00
-35	-31.0	179200.00	242681.00	72804.30	86.25	862.5	574400.00
-30	-22.0	135200.00	176974.00	53092.20	88.22	882.2	413400.00
-25	-13.0	102900.00	130421.00	39126.30	90.19	901.9	300400.00
-20	-4.0	78910.00	97081.00	29124.30	92.16	921.6	220600.00
-15	5.0	61020.00	72957.00	21887.10	94.12	941.2	163500.00
-10	14.0	47540.00	55329.00	16598.70	96.09	960.9	122280.00
-5	23.0	37310.00	42327.00	12698.10	98.04	980.4	92240.00
0	32.0	29490.00	32650.00	9795.00	100.00	1000.0	70160.00
5	41.0	23460.00	25392.00	7617.60	101.95	1019.5	53780.00
10	50.0	18780.00	19901.00	5970.30	103.90	1039.0	41560.00
15	59.0	15130.00	15712.00	4713.60	105.85	1058.5	32340.00
20	68.0	12260.00	12493.00	3747.90	107.79	1077.9	25360.00
25	77.0	10000.00	10000.00	3000.00	109.74	1097.4	20000.00
30	86.0	8194.00	8057.00	2417.10	111.67	1116.7	15892.00
35	95.0	6752.00	6531.00	1959.30	113.61	1136.1	12704.00
40	104.0	5592.00	5326.00	1597.80	115.54	1155.4	10216.00
45	113.0	4655.00	4368.00	1310.40	117.47	1174.7	8264.00
50	122.0	3893.00	3602.00	1080.60	119.40	1194.0	6722.00
55	131.0	3271.00	2986.00	895.80	121.32	1213.2	5498.00
60	140.0	2760.00	2488.00	746.40	123.24	1232.4	4520.00
65	149.0	2339.00	2083.00	624.90	125.16	1251.6	3734.00
70	158.0	1990.00	1752.00	525.60	127.08	1270.8	3100.00
75	167.0	1700.00	1480.00	444.00	128.99	1289.9	2586.00
80	176.0	1458.00	1255.00	376.50	130.90	1309.0	2166.00
85	185.0	1255.00	1070.00	321.00	132.80	1328.0	1822.60
90	194.0	1084.00	915.50	274.65	134.71	1347.1	1540.00
95	203.0	939.30	786.60	235.98	136.61	1366.1	1306.40
100	212.0	816.80	678.60	203.58	138.51	1385.1	1112.60
105	221.0	712.60	587.60	176.28	140.40	1404.0	951.00
110	230.0	623.60	510.60	153.18	142.29	1422.9	815.80
115	239.0	547.30	445.30	133.59	144.18	1441.8	702.20
120	248.0	481.80	389.60	116.88	146.07	1460.7	606.40
125	257.0	425.30	341.90	102.57	147.95	1479.5	525.60
130	266.0	376.40	301.00	90.30	149.83	1498.3	N/A
135	275.0	334.00	265.80	79.74	151.71	1517.1	N/A
140	284.0	297.20	235.30	70.59	153.58	1535.8	N/A
145	293.0	265.10	208.90	62.67	155.46	1554.6	N/A
150	302.0	237.00	186.10	55.83	157.33	1573.3	N/A

Figure 10: Resistance vs Temperature

Series	CDT	-2	N	4	A	4	-LCD	Example: CDTR-2N4A4-LCD
Range		2 5						0 to 2000 ppm CO ₂ range 0 to 5000 ppm CO ₂ range
Configuration			N E					North American Wall Mount European Wall Mount
CO ₂ Output				4				4 to 20 mA / 0 to (5 or 10) VDC
Temperature Output					0 4 A B C D E F			None 4 to 20 mA / 0 to (5 or 10) VDC 10 KΩ NTC thermistor type III 10 KΩ NTC thermistor type II 3 KΩ NTC thermistor Pt100 Ω RTD Pt1000 Ω RTD 20 KΩ NTC thermistor
RH Output						4		4 to 20 mA / 0 to (5 or 10) VDC
Options							LCD RLY NBC	LCD display (wall only) Relay No buttons (wall only)

Figure 8: Series CDTR Model Chart

Menu Descriptions

RON	Relay on set point Sets the CO ₂ concentration which the optional relay is energized.
	Low limit: 0 PPM Factory setting: 1000 PPM High limit: 2000/5000 PPM (depending on model)
ROF	Relay off set point Sets the CO ₂ concentration which the optional relay is de-energized. Setting value lower than RON provides direct action for detecting high concentrations of CO ₂ . Setting value higher than RON provides indirect action for detecting low concentrations of CO ₂ . Up button and Down button on the LCD display will be lit to indicate when the relay is energized.
	Low limit: 0 PPM Factory setting: 950 PPM High limit: 2000/5000 PPM (depending on model)
DSP	Display configuration Determines the LCD display configuration during normal operation. The LCD display can indicate the CO ₂ concentration, temperature, relative humidity (Series CDTR only) and CO ₂ concentration combined with temperature or relative humidity (Series CDTR only).
	CH CO ₂ concentration and relative humidity (Series CDTR only) CT CO ₂ concentration and temperature TH Temperature and relative humidity (Series CDTR only) C CO ₂ concentration only T Temperature only H Relative humidity only (Series CDTR only)
UNI	Units selection Temperature and barometric pressure measurements can be displayed in US engineering units or SI engineering units. The factory default is to display US engineering units.
	US units °F for temperature and in Hg for barometric pressure SI units °C for temperature and hPa for barometric pressure
COL	CO ₂ low output range Sets the CO ₂ concentration for the lowest output (4 mA or 0 VDC).
	Low limit: 0 PPM Factory setting: 0 PPM High limit: 2000/5000 PPM (depending on model)
COH	CO ₂ high output range Sets the CO ₂ concentration for the highest output (20 mA, 5 VDC or 10 VDC). When COH is set above COL, the transmitter is direct acting and the output will increase with an increase in CO ₂ level. When COH is below COL, the transmitter is reverse acting and the output will increase with a decrease in CO ₂ level.
	Low limit: 0 PPM Factory setting: 2000/5000 PPM (depending on model) High limit: 2000/5000 PPM (depending on model)
TOL	Temperature low output range (Series CDT with active temperature only) Sets the temperature for the lowest output (4 mA or 0 VDC).
	Low limit: 32.0°F / 0.0°C Factory setting: 32.0°F / 0.0°C High limit: 122.0°F / 50.0°C
TOH	Temperature high output range (Series CDT with active temperature only) Sets the temperature for the highest output (20 mA, 5 VDC or 10 VDC). When TOH is set above TOL, the transmitter is direct acting and the output will increase with an increase in temperature. When TOH is below TOL, the transmitter is reverse acting and the output will increase with a decrease in temperature.
	Low limit: 32.0°F / 0.0°C Factory setting: 122.0°F / 50.0°C High limit: 122.0°F / 50.0°C

HOL	Humidity low output range (Series CDTR only) Sets the humidity for the lowest output (4 mA or 0 VDC).
	Low limit: 0.0% Factory setting: 0.0% High limit: 100.0%
HOH	Humidity high output range (Series CDTR only) Sets the humidity for the highest output (20 mA, 5 VDC or 10 VDC). When HOH is set above HOL, the transmitter is direct acting and the output will increase with an increase in humidity. When HOH is below HOL, the transmitter is reverse acting and the output will increase with a decrease in humidity.
	Low limit: 0.0% Factory setting: 100.0% High limit: 100.0%
BAR	Barometric pressure Sets the typical barometric pressure for the location where the transmitter is mounted. The factory setting is for standard pressure at sea level. Adjusting the barometric pressure gives a more accurate measurement, especially at higher elevations. Refer to the elevation charts in Figure 9 for typical barometric pressures at a given elevation.
	Low limit: 20.0 in Hg / 677 hPa Factory setting: 29.9 in Hg / 1013 hPa High limit: 32.0 in Hg / 1084 hPa
CAL	Calibration Calibrates the carbon dioxide sensor to a known gas value. Read calibration instructions before using this feature. Hold Enter button for 5 seconds.
RST	Reset to Factory Defaults Resets all menu settings to their default value, and clears zero and span.
	YES - Press & hold -- button for several seconds to reset settings NO - Press -- button to exit this menu item without resetting

CALIBRATING SENSOR

- Step 1: Remove the cover as shown in Figure 1.
- Step 2: Remove one of the gas nipple covers on the CO₂ sensor and attach tubing from the gas pressure regulator to the nipple (See Figure 6).
- Step 3: Attach the terminal block accessory to the circuit board so that the power wires line up with terminals 1 and 2. Plug in the power supply to power up the transmitter.
- Step 4: Hold housing so that the sensor is in the vertical plane as shown in Figure 6.
- Step 5: Follow the steps in the accessing parameter section to access the calibration parameter (CAL).
- Step 6: Press the Enter button.
- Step 7: Flow zero reference gas at 0.3 SLPM for 5 minutes.
- Step 8: Press and hold the Down button for 3 seconds.
- Step 9: Flow the full scale reference gas at 0.3 SLPM for 5 minutes.
- Step 10: Press and hold the Up button for 3 seconds.
- Step 11: Exit the parameter menu.
- Step 12: Disconnect the power supply from the power source and remove the terminal block from the circuit board.
- Step 13: Remove tubing from sensor and re-attach the gas nipple cover to the sensor.
- Step 14: Re-attach the cover to the back plate.

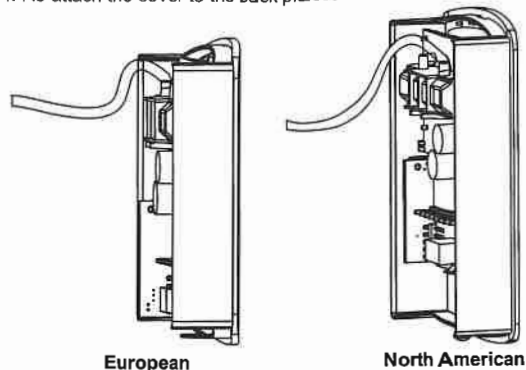

Figure 6: Calibration